

RS

RS







RS



## Oblikovanje podrejeno aerodinamiki

### Cilji:

0 vzgona spredaj in zadaj

Minimalen upor

Maksimalno hlajenje



Cd 0.355 - 6% nižji količnik upora





# Oblikovanje prednjega dela

Paket spojlerjev optimiziran brez vzgona

Največje hladilne odprtine doslej

Posebni kanali za hlajenje zavor

Optimizirana mrežica za zajem zraka  
- 85% porozna proti 56% na ST



ST

RS

RS

# Oblikovanje prednjega dela

Paket spojlerjev optimiziran brez vzgona

Največje hladilne odprtine doslej

Posebni kanali za hlajenje zavor

Optimizirana mrežica za zajem zraka  
- 85% porozna proti 56% na ST

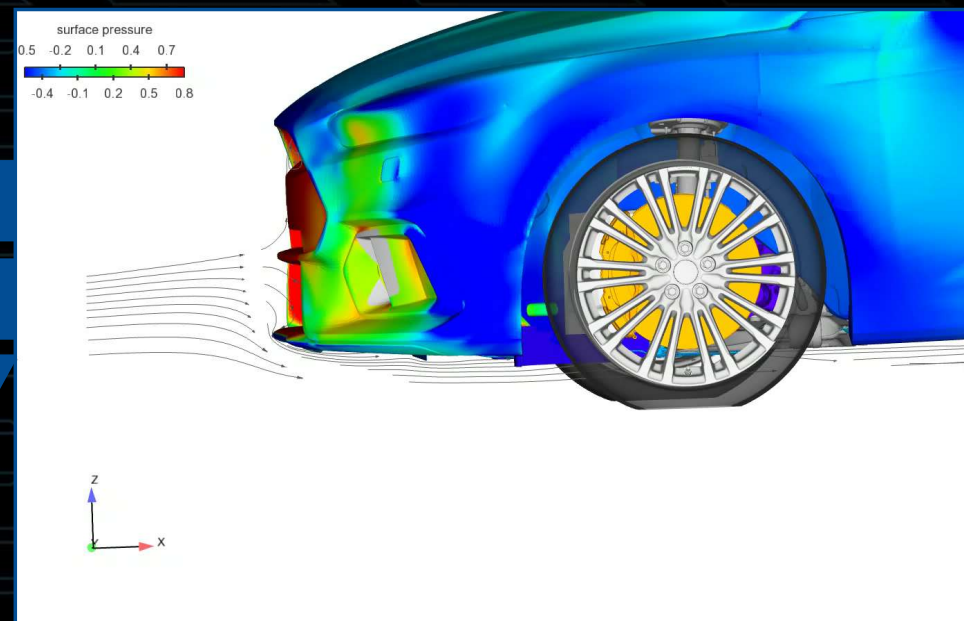

ST

RS

RS



# Oblikovanje zadnjega dela

Velik zadnji difuzor znižaja upor

Unikatni zadnji spojler znižaja vzgon

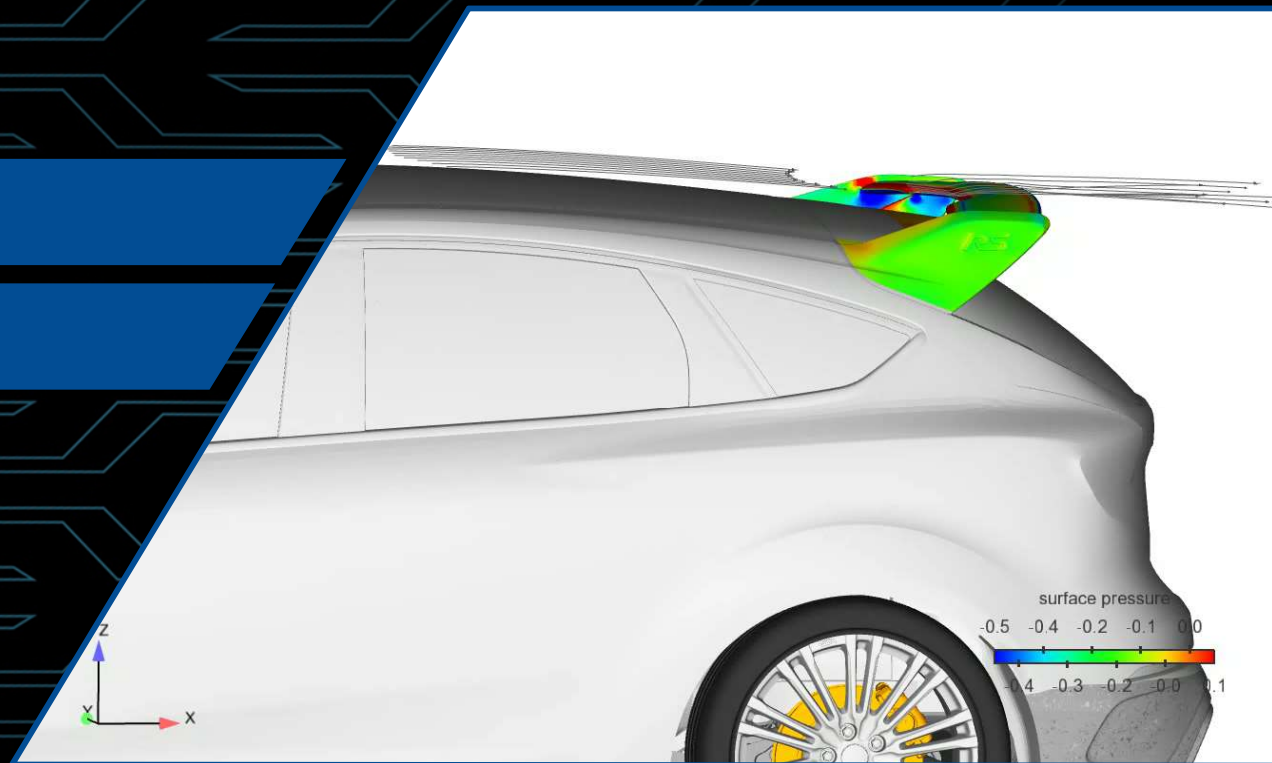





## EcoBoost 2.3 4-valjnik



Enaka arhitektura kot v Mustangu

Predelan za Focus RS

Povečana moč in zmogljivost

Povečana trajnost in hlajenje

Unikatno uglašen

Moč / navor:	350 KM / 440Nm
0 - 100km/h:	4.7 s
Najvišja hitrost:	266km/h
CO2 emisije:	175g/km



# Zvok

Unikaten zvok, ki ustreza karakterju RS

Uglajen zvok dušilnega sistema

Ritem injektorjev, ki dodaja pokanje, brbotanje  
v Sport načinu vožnje



Zvok izpuha – prvotni režim





# Zvok

Unikaten zvok, ki ustreza karakterju RS

Uglajen zvok dušilnega sistema

Ritem injektorjev, ki dodaja pokanje, brbotanje  
v Sport načinu vožnje



Zvok izpuha – končni režim



# AWD z dinamičnim nadzorom vektorjev navora

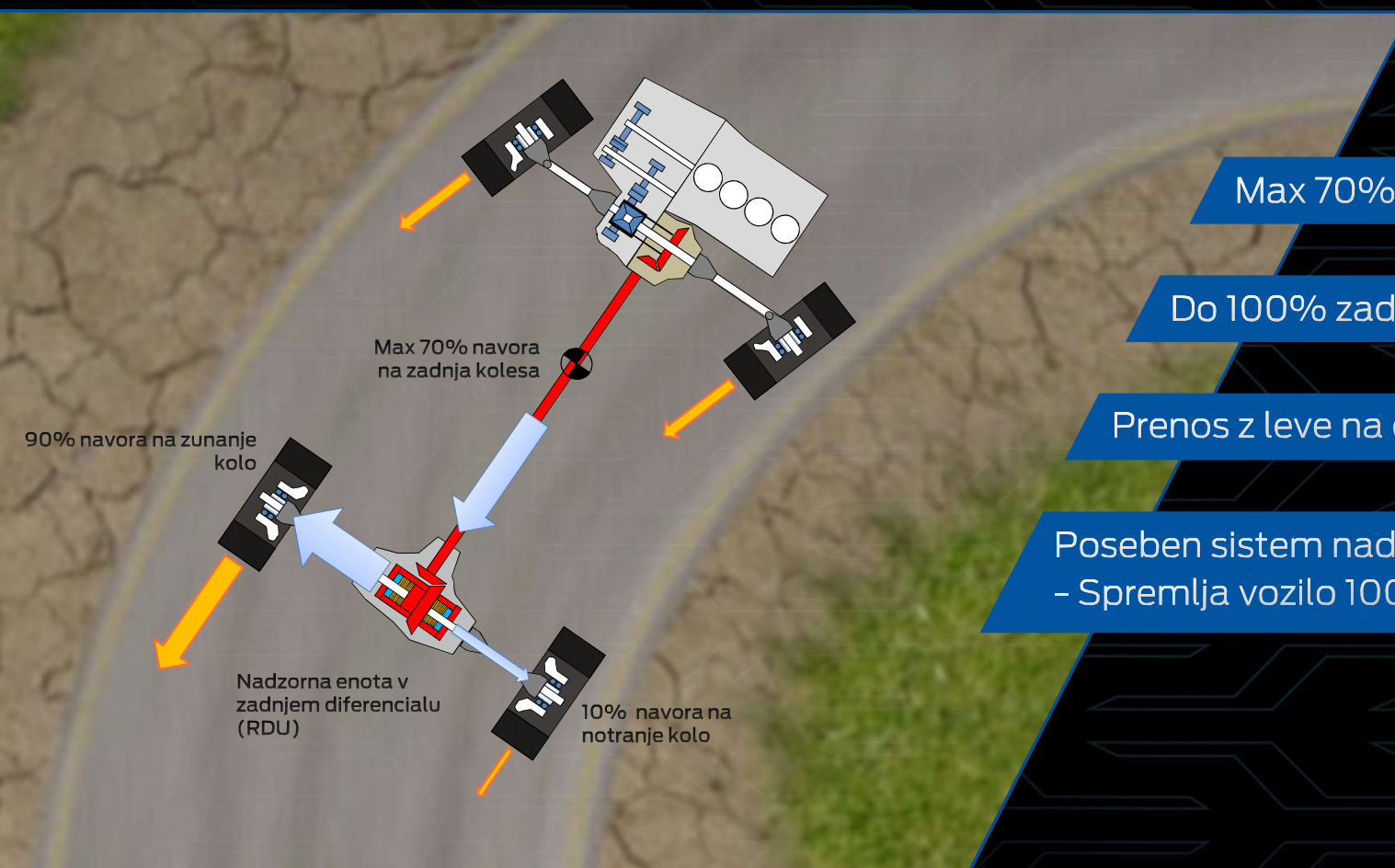

Max 70% navora na zadnja kolesa

Do 100% zadnjega navora na levo ali desno kolo

Prenos z leve na desno zadaj v 0.06 s

Poseben sistem nadzora v zadnjem diferencialu  
- Spremlja vozilo 100 krat v sekundi





Bolj odziven

Užitak v krmiljenju

Višje izhodne hitrosti iz zavojev

Brez podkrmiljenja



# iAWD

Visoke zmogljivosti v ovinkih ( $>1g$ )

Uravnovešeno krmiljenje na meji zdrs

Značaj pogona na zadnja kolesa

Odličen oprijem in izhodna hitrost

Posebne lastnosti:

Različne nastavitve vožnje & Launch Control



RS



# Krmiljenje



Unikaten EPAS nadgrajuje  
Izkušnjo s Focusom ST

Linearni zobnik krmiljenja nizkega trenja  
za bolj natančno krmiljenje

Krajše obratno razmerje kot Focus ST  
- 2.0 obrata volanskega obroča



# Nastavitve krmiljenja – 'Normal' in 'Sport'

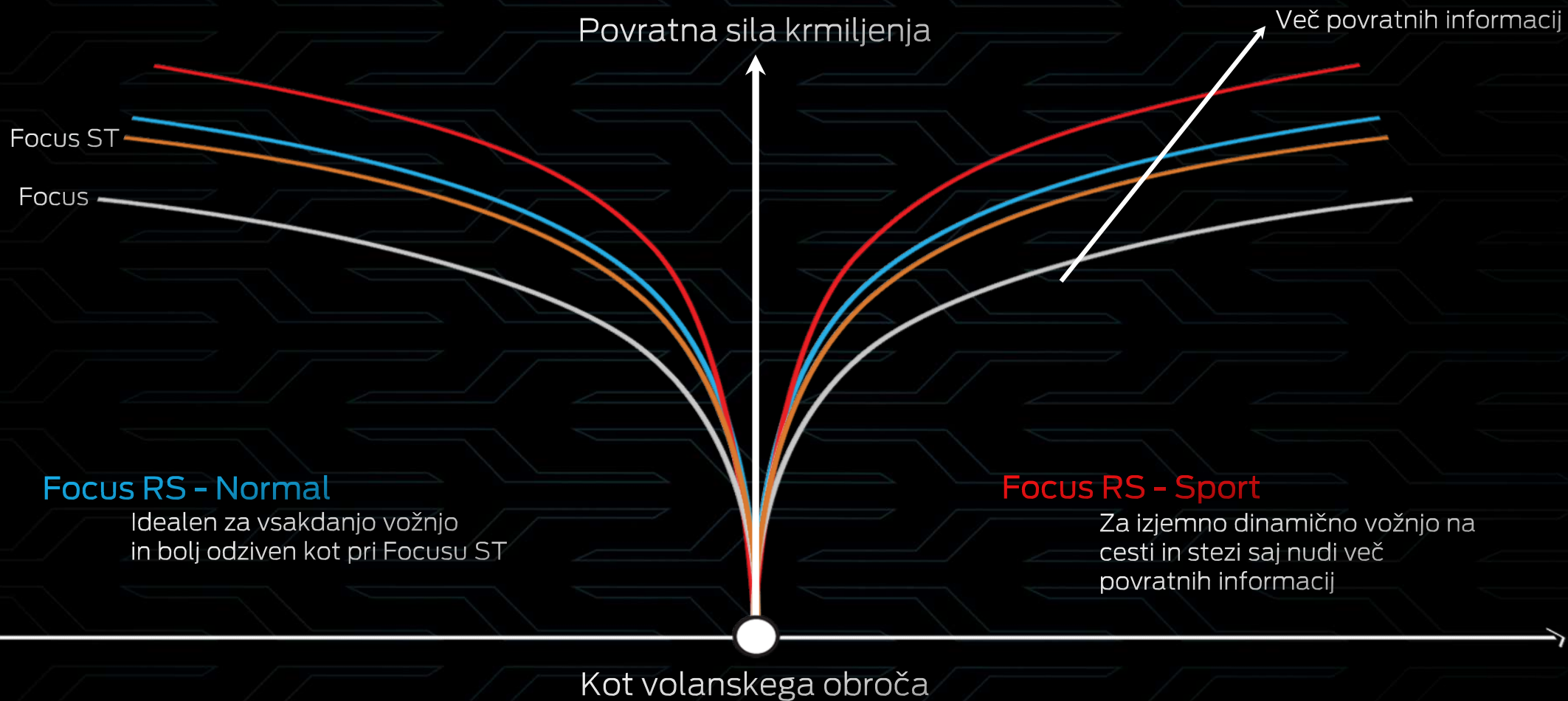



# Zavorni sistem



RS



A close-up photograph of a blue car's front wheel. The wheel is in motion, as indicated by the blurred background. A blue Brembo brake caliper is visible, with the 'brembo' logo on it. The car's body is a vibrant blue color.

Najzmogljivejši zavorni sistem  
doslej na RS modelu

Spredaj:  
350mm viski proti 336mm (2009 RS)

Brembo enodelne čeljusti,  
4x 38mm zavorni bati

4.3kg prihranka na platišče v primerjavi z 2009 RS

Na voljo modre RS čeljusti



# Hlajenje prednjih zavor

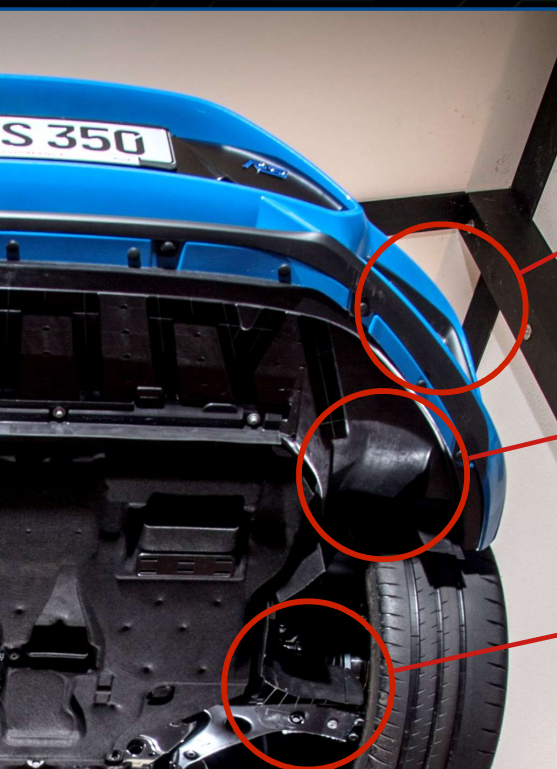

Odprtine za  
zajem zraka



Hladilni tunel

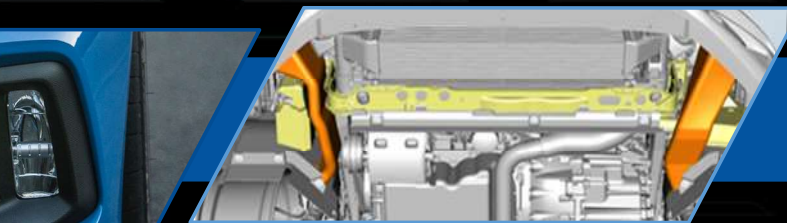

Deflektorji na nosilni roki

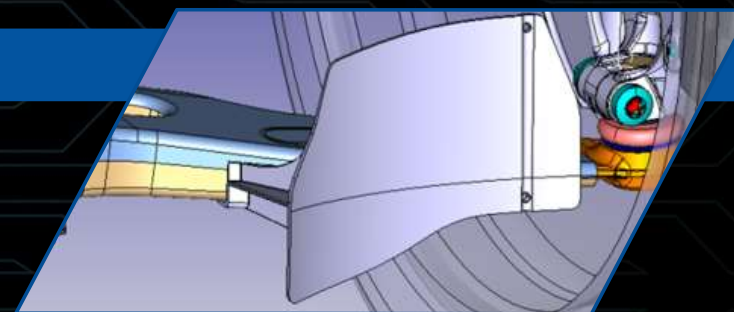
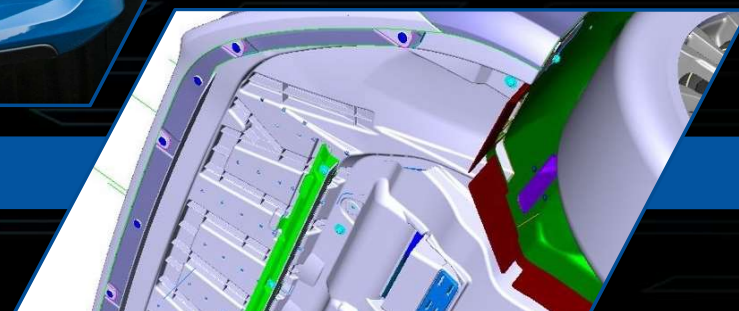

# Zavorni sistem

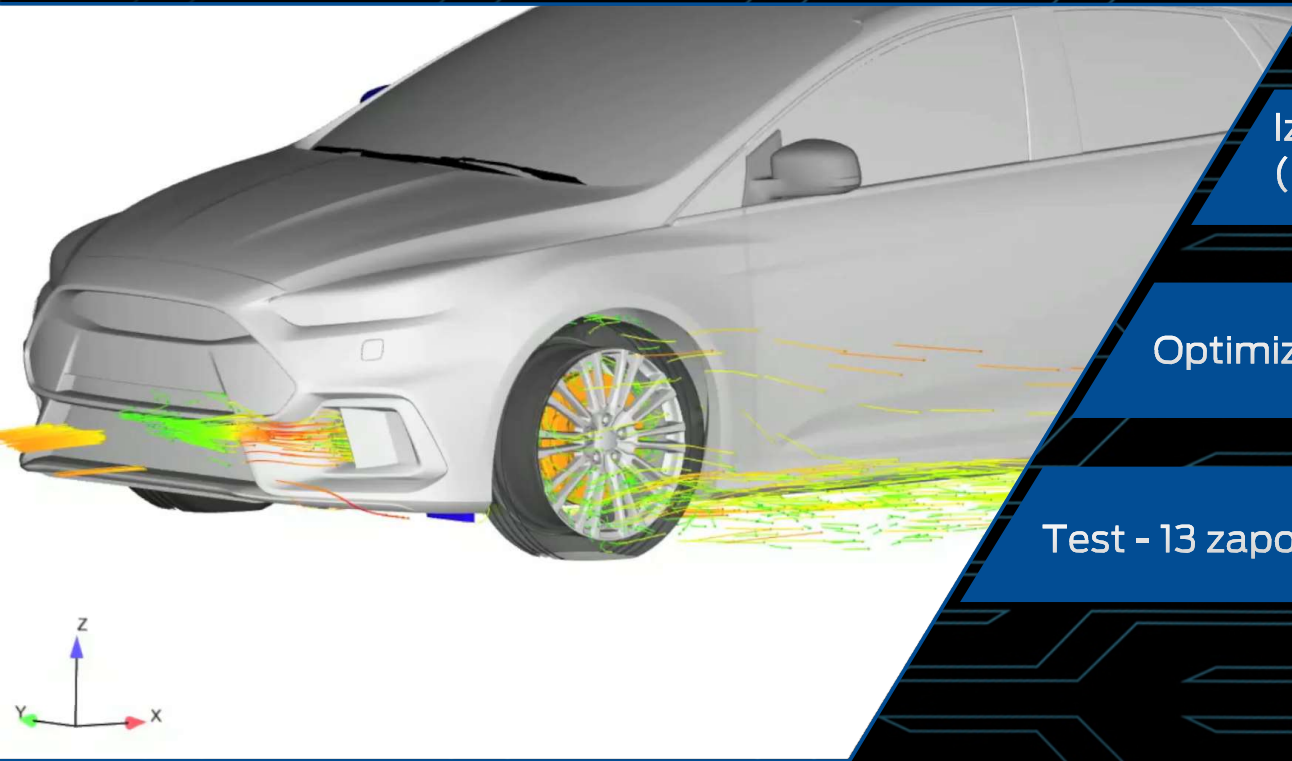

Izboljšán za 20%  
(hlajenje od 350°C do 150°C @100km/h)

Optimizirano za 30 minutne intervale na stezi

Test - 13 zaporednih zaviranj do 0 km/h od 214km/h



# Vzmetenje

Unikatna šasija  
za AWD pogon

**23%**  
Več torzijske  
rigidnosti

Stabilizator  
za zadnjo osjo

Zadaj roka z vpetjem  
'control blade'

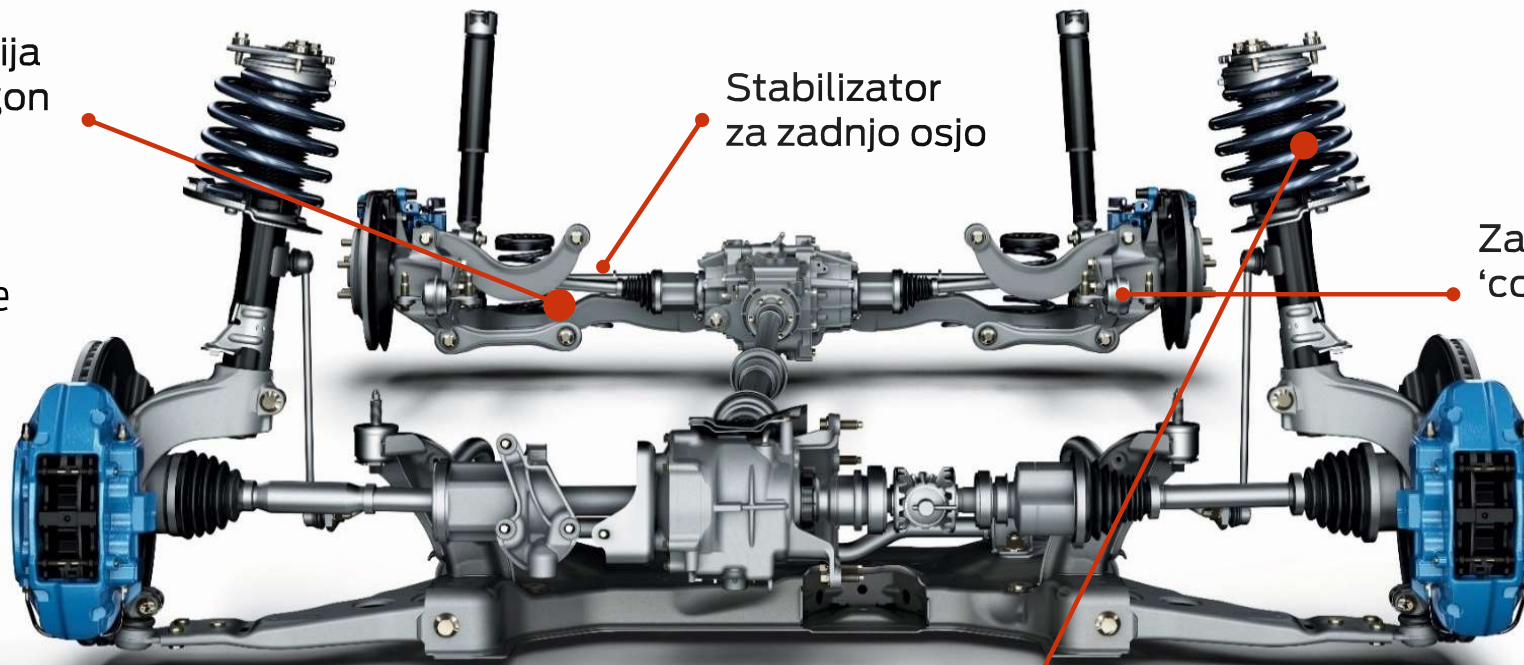

Bolj čvrste vzmeti

**33%**  
spredaj  
**38%**  
zadaj

Spredaj MacPherson sistem  
z optimiziranim sistemom vpetja

# Vzmeti

Bolj čvrste vzmeti kot Focus ST:

Spredaj + 33%

Zadaj + 38%

Bolj učinkovita postavitev zadnjega stabilizatorja

High performance bushes from Focus ST





# 19" RS platišča iz lahke zlitine

Za doplačilo 19" kaljena platišča

950g lažja na platišče

Michelin Pilot Sport Cup 2 pnevmatike



## Vozna dinamika – Drive Modes



Voznik ima na izbiro štiri načine  
- z njimi prilagodi vozilo da ustreza določeni situaciji  
- vozne lastnosti ukrojene za voznike različnih zmožnosti

Izbirni gumb ob prestavni ročici

Normal in Sport za cestno vožnjo

Track in v segmentu prvi Drift za dirkalno stezo

Sistem prilagaja 6 ključnih sistemov v vsaki nastavitvi





# Načini vožnje



Upravlja	Normal	Sport	Track	Drift
AWD	Normal	Sport	Sport	Drift
Blažilci	Normal	Normal	Sport	Normal
Krmiljenje	Normal	Sport	Sport	Normal
Motor	Normal	Sport	Sport	Sport
ESC	Normal	Normal	Sport	Sport
Izpušni ventili	Normal	Sport	Sport	Sport



# Launch Control / opozorilna lučka Performance Shift



Prvi RS z pomočjo pri speljevanju Launch Control za najbolj prepričljive starte

Optimalna nastavitve AWD, optimalne moči, sistema TCS in blažilcev

Performance Shift lučka vas opozori na najbolj primeren trenutek za višjo prestavo



RS



# Udobje in priročnost



RS Recaro sedeža – Recaro Shell za doplačilo

Ford SYNC2

Bi-Xenonska prilagodljiva žarometa

Ford Power gumb za zagon vozila

Pomembne tehnologije udobja in priročnosti na voljo

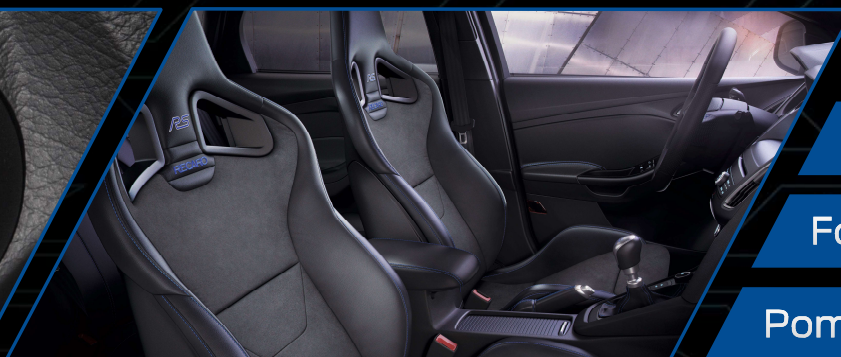



**RS**



**Izjemna zmogljivost**

**Inovativna tehnologija**

**Vrednost**



RS

RS